

# Decora

*HOTEL RESTAURANT & CONTRACT*



Pag. 6 PRESENTAZIONE AZIENDA - COMPANY PROFILE - FIRMENPROFIL - PROFIL DE L'ENTERPRISE

Pag. 7 REFERENZE - REFERENCES - REFERENZEN - RÉFÉRENCES

Pag. 8-36 **SEDUTE**  
SEATINGS  
STÜHLE  
CHAISES



DIANA 114 pag. 8   DIANA 115 pag. 8   DIANA 116 pag. 8   DIANA 118 pag. 8   DIANA 119 pag. 8   DIANA 120 pag. 8   DIANA 121 pag. 8   DIANA 123 pag. 9   DIANA 124 pag. 9

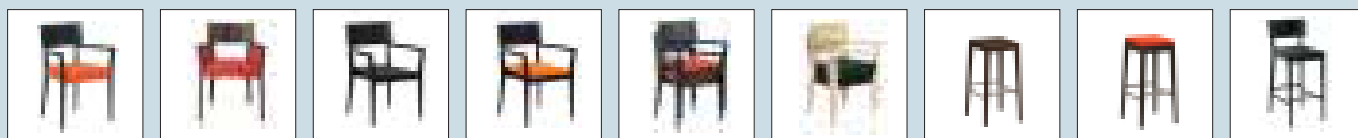

DIANA 125 pag. 9   DIANA 128 pag. 9   DIANA 131 pag. 9   DIANA 132 pag. 9   DIANA 133 pag. 9   DIANA 134 pag. 9   DIANA 136 pag. 10   DIANA 140 pag. 10   DIANA 143 pag. 10



DIANA 144 pag. 10   DIANA 146 pag. 10   DIANA 147 pag. 10



DORA 160 pag. 11   DORA 162 pag. 11   DORA 164 pag. 11   DORA 166 pag. 11   DORA 168 pag. 11



ESTER 175 pag. 12   ESTER 177 pag. 12   ESTER 179 pag. 12   ESTER 181 pag. 12   ESTER 183 pag. 12   ESTER 185 pag. 12   ESTER 187 pag. 13   ESTER 189 pag. 13   ESTER 191 pag. 13



ESTER 193 pag. 13   ESTER 195 pag. 13   ESTER 197 pag. 13   ESTER 199 pag. 13   ESTER 200 pag. 13



FAN 210 pag. 14   FAN 212 pag. 14   FAN 214 pag. 14   FAN 216 pag. 14   FAN 218 pag. 14   FAN 220 pag. 14   FAN 221 pag. 14   FAN 223 pag. 14

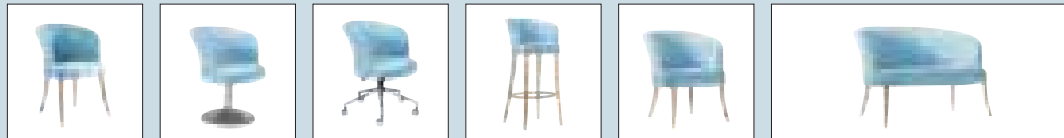

FRED 234 pag. 15   FRED 236 pag. 15   FRED 238 pag. 15   FRED 240 pag. 15   FRED 242 pag. 15   FRED 243 pag. 15



GINA 255 pag. 16   GINA 257 pag. 16   GINA 259 pag. 16   GINA 261 pag. 17   GINA 263 pag. 17   GINA 266 pag. 17   GINA 267 pag. 17



ISA 111 pag. 18   ISA 112 pag. 18   ISA 127 pag. 18   ISA 129 pag. 18   ISA 130 pag. 18   ISA 150 pag. 19   ISA 152 pag. 19   ISA 153 pag. 19   ISA 155 pag. 19



ISA 156 pag. 19



JANE 280 pag. 20   JANE 282 pag. 20   JANE 285 pag. 20   JANE 287 pag. 20

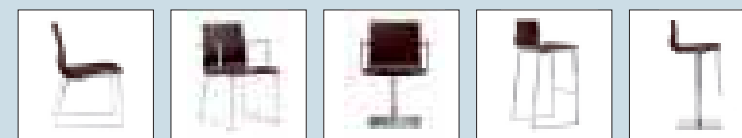

JOAN 300 pag. 21   JOAN 302 pag. 21   JOAN 303 pag. 21   JOAN 304 pag. 21   JOAN 306 pag. 21



KELLY 316 pag. 22   KELLY 318 pag. 22   KELLY 319 pag. 22   KELLY 320 pag. 22   LARA 328 pag. 22

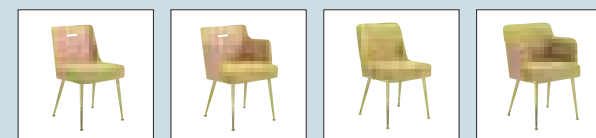

LERRY 338 pag. 23   LERRY 340 pag. 23   LERRY 342 pag. 23   LERRY 344 pag. 23



LISA 354 pag. 24   LOLA 362 pag. 24   LOLA 364 pag. 24   LORNA 367 pag. 24



MAGDA 377 pag. 25   MAGDA 379 pag. 25   MAGDA 381 pag. 25



MARY 392 pag. 26   MARY 394 pag. 26   MARY 396 pag. 26

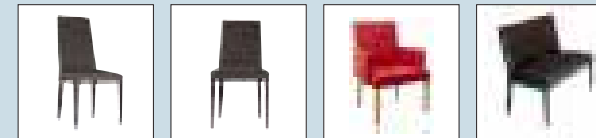

MASHA 420 pag. 27   MASHA 422 pag. 27   MASHA 424 pag. 27   MASHA 426 pag. 27

SEDUTE  
SEATINGS  
STÜHLE  
CHAISES

MEG 460 pag. 28   MEG 462 pag. 28   MEG 464 pag. 28   MEG 466 pag. 28   MEG 468 pag. 28   MEG 470 pag. 28



MOLLY 480 pag. 29   MOLLY 482 pag. 29   MOLLY 484 pag. 29   MOLLY 486 pag. 29   MOLLY 488 pag. 29   MOLLY 490 pag. 29   MOLLY 492 pag. 29   MOLLY 494 pag. 29



NADA 504 pag. 30   NADA 506 pag. 30



NED 516 pag. 31   NED 518 pag. 31



NICO 528 pag. 32   NICO 530 pag. 32   NICO 532 pag. 32



NORA 404 pag. 33   NORA 405 pag. 33   NORA 406 pag. 33   NORA 407 pag. 33

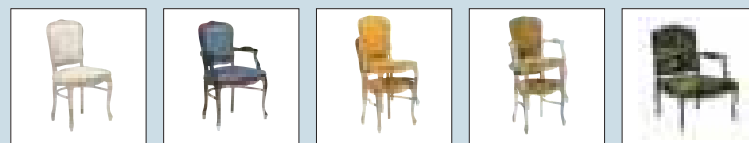

ODEON 440 pag. 34   ODEON 441 pag. 34   ODEON 442 pag. 34   ODEON 444 pag. 34   ODEON 446 pag. 34



OLLY 430 pag. 35   OLLY 431 pag. 35   OLLY 433 pag. 35   OLLY 434 pag. 35   OLLY 436 pag. 35   OLLY 437 pag. 35



OMEGA 415 pag. 36   OMEGA 416 pag. 36   OXY 412 pag. 36   OXY 413 pag. 36   PAOLA 656 pag. 36

Pag. 37-39 BASI TAVOLO  
TABLE BASES  
TISCHSÄULEN  
PIÈTEMENTS

INOX.R pag. 37   INOX.R pag. 37   INOX.T pag. 37   INOX.X pag. 37

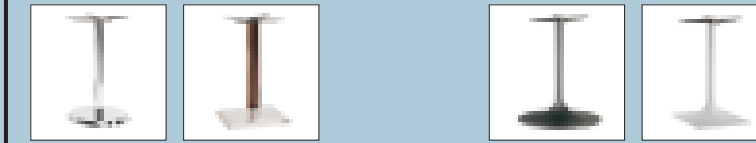

MARA pag. 38   MARA pag. 38   NEW pag. 38   NEW pag. 38

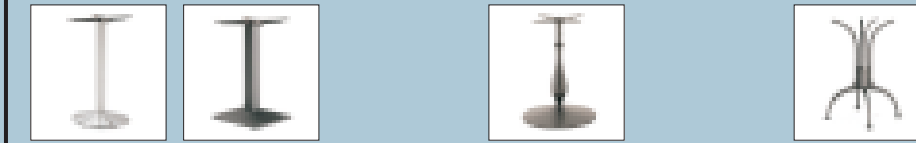

ONDA pag. 39   ONDA pag. 39   RANDA pag. 39   SILA pag. 39

Pag. 40-41 PIANI TAVOLO  
TABLES TOPS  
TISCHPLATTEN  
PLATEAUX  
DES TABLES

TOPL pag. 40   TOPM pag. 40   TOPS pag. 40



TOPT pag. 41   TOPV pag. 41   TOPW pag. 41   TOPX pag. 41

Pag. 42 TAVOLI  
E TAVOLINI  
TABLES  
TISCHE  
TABLES

SALA pag. 42   SILVA pag. 42   SILVA pag. 42   TED pag. 42   TED pag. 42

FINITURE  
RIVESTIMENTI  
MATERIALI  
FINISHES  
COVERINGS  
MATERIALS  
AUSFÜHRUNGEN  
STOFFEN  
FARBEN  
FINITIONS  
TISSUES  
MATÉRIAUX

FINITURE SU LEGNO - FINISHES ON WOOD - HOLZFARBEN - FINITIONS SUR BOIS pag. 44

RIVESTIMENTI PER SEDUTE - COVERINGS FOR SEATING - STOFFEN FÜR STÜHLEN - TISSUES POUR CHAISES pag. 45

FINITURE PER BASI TAVOLO - FINISHES FOR TABLE BASES  
AUSFÜHRUNGEN FÜR TISCHSÄULEN - FINITIONS POUR PIÈTEMENTS pag. 46

LAMINATI PLASTICI - PLASTIC LAMINATES - SCHICHTSTOFFEN - STRATIFIÉS pag. 47

STRATIFICATI E TERMOFORMATI - HPL LAMINATES AND HEAT MOULDED TOPS  
KOMPAKTPLATTEN UND HEISSE FORMTENPLATTES - STRATIFIÉS FORT-EPAISSEUR ET THERMOFORMÉS pag. 48

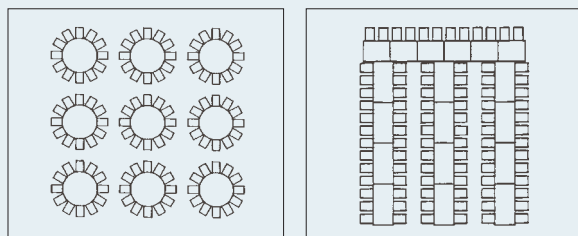
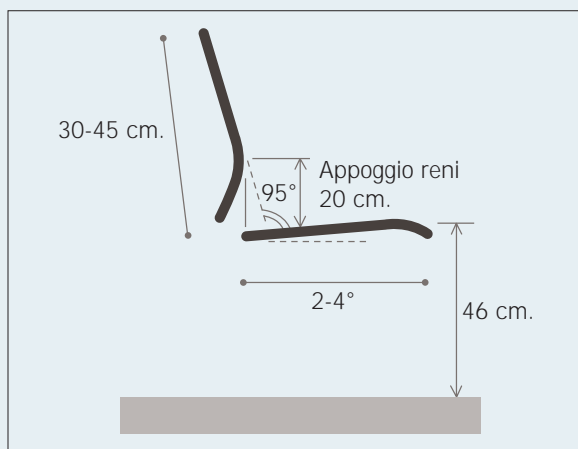

Operiamo ormai da tre generazioni nel settore delle sedute e dei tavoli per ristoranti, bar, alberghi, navi e collettività in generale, con una continua ricerca nel campo della progettazione e del design per proporre prodotti rispondenti alle esigenze di un mercato sempre più esigente e qualificato.

I nostri prodotti, grazie all'utilizzo di materiali scelti e all'adozione di tecniche di costruzione all'avanguardia, sono funzionalmente perfetti, esteticamente piacevoli e, allo stesso tempo, di lunga durata. La nostra estrema flessibilità e la capacità di adattarci alle esigenze del cliente, ci consente di risolvere praticamente ogni richiesta.

*We have been operating for three generations in the manufacture of seatings and tables for restaurants, bars, hotels, ships and communal facilities in general. We carry out continuous research in planning and design to propose products which always respond to the requirements of an increasingly demanding and qualified market.*

*Our use of choice materials and the adoption of first-rank constructions techniques enables us to offer products which are functionally perfect, aesthetically attractive and long-lasting.*

*Our extreme flexibility and skill adapting to the requirements of the customer also enables us to resolve the practical aspects of all requests.*

Seit drei Generationen beschäftigen wir uns mit Sitzmöbeln und Tischen für Restaurants, Bars, Hotels, Schiffe und Großprojekte im allgemeinen. Wir waren stets bemüht, durch intensive Studien eine Weiterentwicklung von Technik und Design unserer Entwürfe zu erreichen, um den Bedürfnissen eines immer anspruchsvolleren, qualifizierten Marktes zu entsprechen. Dank der Anwendung fortschrittlichster Konstruktionstechniken sind unsere Produkte höchst zweckmäßig, optisch ansprechend und gleichzeitig äußerst haltbar.

Durch unsere hohe Flexibilität und Anpassungsfähigkeit an die Bedürfnisse der Benutzer, sind wir in der Lage praktisch alle Ansprüche zu erfüllen.

*Nous opérons désormais depuis trois générations dans le secteur des sièges et tables pour restaurants, hôtels, paquebots et collectivités en général, avec une recherche permanente sur le plan du projet et du design pour proposer des produits répondant aux besoins d'un marché de plus en plus exigeant et qualifié. Comme nous utilisons des matériaux de choix et des techniques de fabrication d'avant-garde, nos produits correspondent exactement à l'usage que l'on doit en faire; ils sont agréables à voir et résistants à l'usure du temps, en même temps.*

*La grande flexibilité qui caractérise notre production et notre capacité d'adaptation aux exigences du client nous permet de trouver des solutions pratiques à tous les problèmes.*

#### ITALIA / ITALY

Mc Donald's, Torino  
 Hotel Genio, Torino  
 Ristorante La Torre, Casale Monferrato (Al)  
 Hotel Principe, Cuneo  
 Hotel Ristorante Europa, Novara  
 Sandys SpA, Bellinzago (No)  
 Courmaison Club Resort, Prè Saint Didier (Ao)  
 Hotel Colibrì, Finale Ligure (Sv)  
 Hotel Tirreno, Spotorno (Sv)  
 Grand Hotel et de Milan, Milano  
 Radisson SAS Scandinavia Hotel, Milano  
 Ristorante Ciao, Milano  
 Mc Donald's, Milano  
 Holiday Inn Assago, Assago (Mi)  
 Clinica Città di Monza, Monza (Mi)  
 Crowne Plaza Hotel, S.Donato M. (Mi)  
 Cosmo Hotel, Vimercate (Mi)  
 Starhotel Cristallo Palace, Bergamo  
 Albergo S.Martino, Boario Terme (Bs)  
 Hotel Touring, Boccaglio (Bs)  
 Ristorante La Speranzina, Sirmione (Bs)  
 Albergo Tre Re, Sesto Calende (Va)  
 Hotel America, Trento  
 Golf Hotel, Madonna di Campiglio (Tn)  
 Hotel Dahu, Madonna di Campiglio (Tn)  
 Hotel Dolomiti, Molveno (Tn)  
 Hotel Europeo, Pinzolo (Tn)  
 Hotel Restaurant Schönblick, Jenesien (Bz)  
 RH Antares, Selva Gardena (Bz)  
 Hotel Cipriani, Venezia  
 Hotel Aurea, Venezia  
 Ristorante Ai Gondolieri, Venezia  
 Hotel Villa Mabapa, Lido di Venezia  
 Ville del Lido, Lido di Venezia  
 Hotel Capitol, Venezia Mestre  
 Hotel Michelangelo, Venezia Mestre  
 Antony Palace Hotel, Venezia Mestre  
 Regent's Hotel, Jesolo Lido (Ve)  
 Holiday Inn Venezia, Marghera (Ve)  
 Sporthotel all'Ancora, Meolo (Ve)  
 Hotel Terme Miramonti, Montegrotto Terme (Pd)  
 Hotel Ca' del Galletto (Tv)  
 Mc Donald's, Verona  
 Club House Matilde d.Canossa, Peschiera d.Garda (Vr)  
 Golf Hotel Paradiso, Peschiera del Garda (Vr)  
 Hotel Brolo, Peschiera del Garda (Vr)  
 Holiday Inn Vicenza, Vicenza  
 Holiday Inn Trieste Duino, Duino (Ts)  
 Trattoria Luka, S.Floriano del Collio (Go)  
 Albergo Florida, Lignano Sabbiadoro (Ud)  
 Holiday Inn Bologna Via Emilia, Bologna  
 Holiday Inn Bologna San Lazzaro, Bologna  
 Ristorante Ciao, Casalecchio di Reno (Bo)  
 Ristorante La Piazza, Ferrara  
 Ristorante Ciao, Ferrara  
 Hotel della Città et de la Ville, Forlì

Hotel Tosco Romagnolo, Bagno di Romagna (Fo)  
 Hotel Executive, Fiorano Modenese (Mo)  
 Hotel Lungarno, Firenze  
 Hotel Victoria, Firenze  
 Caffè Italiano, Firenze  
 Hotel Ibis Campi Bisenzio, Campi Bisenzio (Fi)  
 Holiday Inn Florence North, Campi Bis.o (Fi)  
 Pasticceria Fabbrini, Figline V.no (Fi)  
 Florence Residence Hotel, Scandicci (Fi)  
 Hotel da Vinci, Vinci (Fi)  
 Caffè degli Ignoranti, Castiglion F. (Ar)  
 Hotel Il Pellicano, Porto Ercole (Gr)  
 Hotel Touring, Pisa  
 Art Hotel, Prato  
 Hotel Milano, Prato  
 Hotel Ristorante Le Fontanelle, Prato  
 Art Hotel Mirò, Calenzano (Po)  
 Hotel degli Ulivi, Siena  
 Castello di Fonterutoli, Castellina in Ch. (Si)  
 Hotel Promenade, Montesilvano Sp. (Pe)  
 Hotel Bella Magione, Magione (Pg)  
 Villa Rosalba, Montecatilli (Tr)  
 Hotel Visconti Palace, Roma  
 Hotel Bernini Bristol, Roma  
 Empire Palace Hotel, Roma  
 Hotel Fourtyseven, Roma  
 Hotel Celio, Roma  
 Hotel Napoleon, Roma  
 Ristorante La Borghesiana, Roma  
 Ristorante Anni 50, Roma  
 Oly Hotel, Roma  
 Grand Hotel Tiberio, Roma  
 Hotel Sisto V°, Roma  
 Hotel Napoleon, Roma  
 Hotel Brasile, Roma  
 Olympic Hotel, Roma  
 Hotel Quisisana, Roma  
 Hotel Piccadilly, Roma  
 Hotel Gabriella, Roma  
 Ristorante Ciao Cinecittà, Roma  
 Istituto Madri Pie, Roma  
 Mc Donald's, Roma  
 Hotel S.Prisca, Roma  
 Hotel Colonna, Frascati (Roma)  
 Hotel Selene, Pomezia (Roma)  
 Hotel Pietra di Ponente, Velletri (Roma)  
 Hotel Terme Nuova Suio, Suio Terme (Lt)  
 Hotel Mediterraneo, Napoli  
 Albergo Paradiso, Napoli  
 Hotel Panorama, Meta (Na)  
 Hotel Villa Maria, Sorrento (Na)  
 Ristorante Tasso, Sorrento (Na)  
 Hotel Sakura, Torre del Greco (Na)  
 Hotel Civita, Atripalda (Av)  
 Hotel Schuhmann, Paestum (Sa)  
 Grand Hotel Leon d'Oro, Bari  
 Hotel Excelsior Congressi, Bari

Caffè Italiano, Bari  
 Hotel dei Trulli, Alberobello (Ba)  
 Hotel dei Cavalieri, Barletta (Ba)  
 Rist. Poggio del Sole, Castellana G. (Ba)  
 La Castellinaria, Polignano a Mare (Ba)  
 Hotel Rist. Salsello, Risceglie (Ba)  
 La Tavola di Ricciardi, Adria (Ba)  
 Centro S.Paolo, Martinafranca (Ta)  
 Holiday Inn Palermo, Palermo  
 Hotel Principe di Villafranca, Palermo  
 Hotel Naxos Beach, Giardini Naxos (Me)  
 Sant'Alphio Garden Hotel, Giardini Nax. (Me)  
 Villa Jasmine, S. Pier Niceto (Me)  
 Hotel Ariston, Taormina (Me)  
 Holiday Inn Siracusa, Siracusa  
 Antiche Saline, Marsala (Tp)  
 Yacht Marina Hotel, Pantelleria (Tp)  
 Caesar's Hotel, Cagliari  
 La Rinascente, Cagliari  
 Hotel Santelmo, Castiadas (Ca)  
 Villaggio Santagiusta, Castiadas (Ca)  
 Aquadulci Hotel, Domus de Maria (Ca)  
 Hotel Forte Village, Pula (Ca)  
 Hotel Flamingo, S.Margherita di Pula (Ca)  
 Hotel Arbatasar, Uta (Ca)  
 Hotel Ala Birdi, Arborea (Or)

#### AUSTRIA / AUSTRIA

Austria Trend Hotel Ananas, Wien  
 Flughafen Wien, Wien Schwechat

#### BELGIO / BELGIUM

Jolly Hotel Du Grand Sablon, Bruxelles  
 Hyillit Hotel, Antwerpen

#### CROAZIA / CROATIA

Hotel Croatia, Cavtat  
 Hotel Excelsior, Dubrovnik  
 Gradska Kavarna, Dubrovnik  
 Hotel Albatros, Porec

#### GERMANIA / GERMANY

Waldhotel Riederin, Bodenmais  
 Detmolder Hof, Detmold  
 Hotel Haidmühler Hof, Heidmühl  
 Restaurant Meisterhaus, Unna

#### GRAN BRETAGNA / GREAT BRITAIN

Cafè Moca, London  
 Rugby Footbal Union, Twickenham  
 Restaurant The Quay, Poole

#### REPUBBLICA CECA / CZECH REPUBLIC

Hotel Ambassador, Praha  
 Rist. Alla Bella Italia, Praha

#### SLOVENIA / SLOVENIA

Hotel Cerkno, Cerkno



DIANA 114



DIANA 115



DIANA 118



DIANA 119



DIANA 121



DIANA 123



DIANA 124



DIANA 128



DIANA 131



DIANA 132



DIANA 116



DIANA 120



DIANA 133



DIANA 134



DIANA 125

MOD.	H	A	H	h	h
DIANA 114	83	43	46	46	—
DIANA 115	83	43	46	47	—
DIANA 116	83	43	46	48	—
DIANA 118	83	48	50	48	—
DIANA 119	83	43	46	46	4
DIANA 120	83	43	46	48	4
DIANA 121	83	43	46	48	4

MOD.	H	A	H	h	h	h
DIANA 123	83	58	50	46	66	—
DIANA 124	83	58	50	47	66	—
DIANA 125	83	58	50	48	66	—
DIANA 128	83	58	50	48	66	—
DIANA 131	83	59	50	46	66	4
DIANA 132	83	59	50	47	66	4
DIANA 133	83	59	50	48	66	4
DIANA 134	83	59	50	48	66	4



DIANA 147



DIANA 143



DIANA 144



DIANA 136



DIANA 140



DIANA 146

MOD.	h	l	h	h	h	h
DIANA 136	80	40	40	80	-	-
DIANA 140	83	40	40	83	-	-
DIANA 143	112	43	48	80	-	-
DIANA 144	112	43	48	83	-	-
DIANA 146	83	67	58	42	65	-
DIANA 147	83	67	58	42	65	-



DORA 164

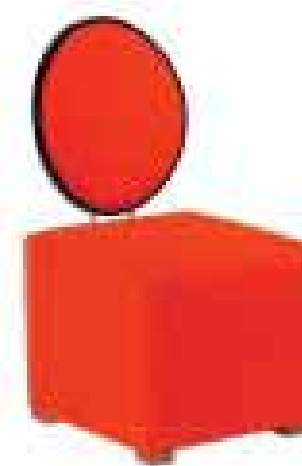

DORA 162



DORA 160



DORA 168



DORA 166

MOD.	h	l	h	h	h	h
DORA 160	90	49	57	49	-	-
DORA 162	86	45	52	44	-	-
DORA 164	90	56	57	49	67	-
DORA 166	123	48	52	77	-	-
DORA 168	99	62	64	49	67	-



ESTER 175



ESTER 181



ESTER 193



ESTER 191

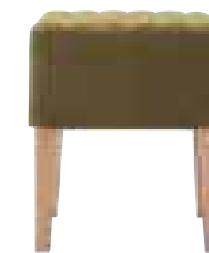

ESTER 187

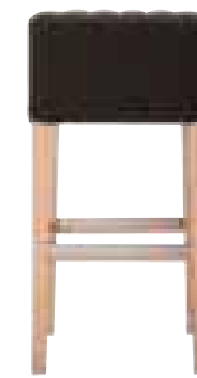

ESTER 189



ESTER 199



ESTER 200



ESTER 177



ESTER 183



ESTER 179



ESTER 185



ESTER 195



ESTER 197

MOD.	h	A	h	h	h	h
ESTER 175	94	51	52	47	—	—
ESTER 177	94	51	52	47	—	—
ESTER 179	107	51	56	47	—	—
ESTER 181	94	62	53	47	67	—
ESTER 183	94	62	53	47	67	—
ESTER 185	107	62	57	47	67	—

MOD.	h	A	h	h	h	h
ESTER 187	45	39	39	45	—	—
ESTER 189	75	39	39	75	—	—
ESTER 191	45	116	39	45	—	—
ESTER 193	45	116	116	45	—	—
ESTER 195	106	44	49	77	—	—
ESTER 197	106	44	49	77	—	—
ESTER 199	87	75	63	44	63	—
ESTER 200	87	139	66	44	63	—





FAN 210



FAN 214



FAN 212



FAN 216



FAN 221



FAN 220



FAN 218



FAN 223

MOD.	h	A	h	h	h	h
FAN 210	85	48	54	47	-	-
FAN 212	85	53	57	47	-	4
FAN 214	85	63	56	47	67	-
FAN 216	85	61	57	47	67	4
FAN 218	107	46	53	76	-	-
FAN 220	85	70	73	47	67	-
FAN 221	85	130	73	47	67	-
FAN 223	40	54	54	40	-	-



FRED 240



FRED 236



FRED 238



FRED 242



FRED 243



FRED 234

MOD.	h	A	h	h	h	h
FRED 234	81	61	61	47	-	-
FRED 236	81	61	61	47	-	-
FRED 238	81	61	61	47	-	-
FRED 240	104	52	53	78	-	-
FRED 242	83	70	70	48	-	-
FRED 243	83	140	70	48	-	-





GINA 255

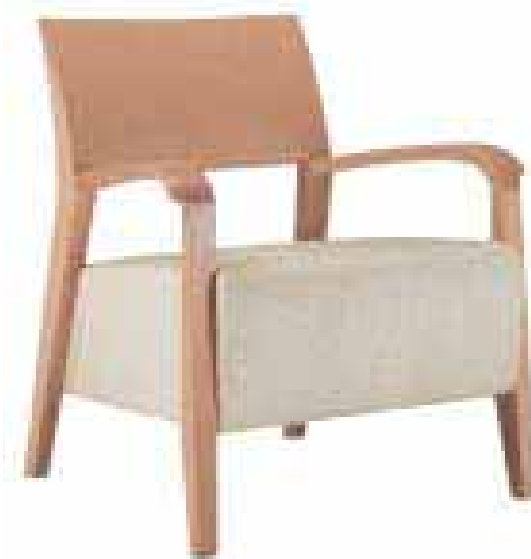

GINA 266



GINA 257



GINA 259



GINA 266



GINA 267



GINA 257

MOD.	H	A	H	H	A	H
GINA 255	86	50	56	48	-	-
GINA 257	86	63	60	48	66	-
GINA 259	104	43	53	75	-	-

MOD.	H	A	H	H	A	H
GINA 261	46	60	60	46	-	-
GINA 263	46	120	60	46	-	-
GINA 266	81	75	74	42	58	-
GINA 267	81	137	74	42	58	-



GINA 261



GINA 263



ISA 111

ISA 112



ISA 130

ISA 129



ISA 152

ISA 153

ISA 150



ISA 127



ISA 155



ISA 156

MOD.	h	A	h	h	h	h
ISA 111	84	49	54	47	-	-
ISA 112	84	49	54	46	-	3
ISA 127	84	57	63	47	65	-
ISA 129	84	57	61	45	65	-
ISA 130	84	57	61	45	65	-

MOD.	h	A	h	h	h	h
ISA 150	50	46	46	50	-	-
ISA 152	108	48	57	76	-	-
ISA 153	108	48	57	76	92	-
ISA 155	84	68	68	43	65	-
ISA 156	84	121	70	43	65	-



JANE 280



JANE 282



JOAN 300



JOAN 302



JANE 285



JANE 287



JOAN 304

JOAN 306



JOAN 303

MOD.	h	A	h	h	A	h
JANE 280	90	44	51	46	—	—
JANE 282	90	58	51	46	66	—
JANE 285	119	44	58	77	—	—
JANE 287	119	58	58	77	96	—

MOD.	h	A	h	h	A	h
JOAN 300	82	47	55	46	—	—
JOAN 302	82	52	55	46	69	—
JOAN 303	82	52	53	46	69	—
JOAN 304	99	41	49	75	—	—
JOAN 306	82/102	40	45	58/83	—	—



KELLY 316



KELLY 318



LERRY 342



LERRY 344



KELLY 319



KELLY 320



LARA 328

MOD.	h	A	h	h	h
KELLY 316	82	47	52	46	—
KELLY 318	82	47	52	46	—
KELLY 319	97	43	45	77	—
KELLY 320	73/98	36	44	54/79	—

MOD.	h	A	h	h	h
LARA 328	88	52	55	46	—

MOD.	h	A	h	h	h	h
LERRY 338	82	48	55	48	—	—
LERRY 340	82	53	56	48	70	—
LERRY 342	82	48	55	48	—	—
LERRY 344	82	53	56	48	70	—



LERRY 340



LERRY 338



LISA 354



MAGDA 377



MAGDA 377



LOLA 362



LOLA 362



LOLA 364



MAGDA 381



MAGDA 379



LORNA 367

MOD.	H	A	H	H	H
LISA 354	61	47	58	44	-

MOD.	H	A	H	H	H	H
LOLA 362	84	49	61	47	-	-
LOLA 364	84	61	61	47	66	-

MOD.	H	A	H	H	H
LORNA 367	84	44	52	45	8

MOD.	H	A	H	H	H	H
MAGDA 377	83	47	57	47	-	-
MAGDA 379	83	47	57	47	-	-
MAGDA 381	83	62	57	47	66	-



MARY 392



MARY 392



MARY 396



MARY 394



MARY 394

MOD.	h	h	h	h	h	h
MARY 392	93	48	56	48	—	—
MARY 394	93	56	56	48	66	—
MARY 396	104	46	50	74	—	—



MASHA 422



MASHA 420



MASHA 424

MOD.	h	h	h	h	h	h
MASHA 420	101	47	56	47	—	—
MASHA 422	91	47	54	47	—	—
MASHA 424	90	59	59	45	66	—
MASHA 426	88	104	59	47	—	—



MASHA 426



MEG 468



MEG 462



MEG 470



MEG 464



MEG 466



MEG 460



MOD.	h	P	h	h	h	h
MEG 460	86	43	48	45	-	-
MEG 462	86	43	48	46	-	-
MEG 464	86	43	48	45	-	-
MEG 466	86	57	48	45	66	-
MEG 468	86	50	48	45	65	-
MEG 470	108	42	45	82	-	-



MOLLY 480



MOLLY 482



MOLLY 484



MOLLY 486



MOLLY 488



MOLLY 490

MOD.	h	P	h	h	h	h
MOLLY 480	97	45	53	46	-	-
MOLLY 482	97	56	53	46	67	-
MOLLY 484	107	44	52	77	-	-
MOLLY 486	97	45	53	46	-	-
MOLLY 488	97	56	53	46	67	-
MOLLY 490	107	44	52	77	-	-
MOLLY 492	97	45	53	46	-	-
MOLLY 494	97	45	53	46	-	-



MOLLY 492



MOLLY 494



NADA 504



NED 516



NADA 506



NED 518

MOD.	h	A	h	h	h	h
NADA 504	88	61	60	46	67	—
NADA 506	105	61	67	46	67	—

MOD.	h	A	h	h	h	h
NED 516	88	45	52	47	—	—
NED 518	88	45	52	47	4	—





NICO 532



NORA 407



NORA 406



NICO 528



NICO 530

MOD.	h	A	h	h	A	h
NICO 528	107	56	59	49	65	-
NICO 530	107	66	59	49	-	-
NICO 532	98	75	60	43	66	-



NORA 404

MOD.	h	A	h	h	A	h
NORA 404	88	49	55	45	-	4
NORA 405	88	55	55	45	67	4
NORA 406	88	55	55	45	67	4
NORA 407	98	55	58	45	67	4



NORA 405





ODEON 440



ODEON 441



ODEON 442



ODEON 444



ODEON 446



OLLY 430



OLLY 431

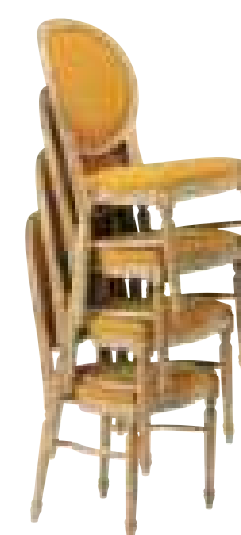

OLLY 433



OLLY 434

MOD.	H	A	H	H	H	H
ODEON 440	95	50	56	47	-	-
ODEON 441	95	60	57	47	68	-
ODEON 442	95	50	56	47	-	4
ODEON 444	95	60	57	47	68	4
ODEON 446	91	69	70	43	65	-

MOD.	H	A	H	H	H	H
OLLY 430	96	50	58	47	-	-
OLLY 431	96	56	58	47	70	-
OLLY 433	96	50	58	47	-	4
OLLY 434	95	59	62	47	70	4
OLLY 436	113	45	50	72	-	-
OLLY 437	96	118	58	47	70	-



OLLY 437



OLLY 436



OMEGA 415



OMEGA 416



OXY 413



OXY 412



PAOLA 656

MOD.	H	A	h	h	H	h
OMEGA 415	102	51	60	47	-	-
OMEGA 416	102	57	60	47	66	-
MOD.	H	A	h	h	H	h
OXY 412	92	50	57	47	-	-
OXY 413	92	58	57	47	68	-
MOD.	H	A	h	h	H	h
PAOLA 656	91	40	49	47	6/10	-

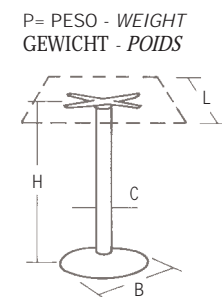

MOD.	670	671	672
H cm.	73	73	73
P Kg.	12,5	16	25
B cm.	Ø 40	Ø 45	Ø 60
C mm.	Ø 60	Ø 76	Ø 76
L cm.	max Ø 70	max Ø 90	max Ø 130



INOX.R



INOX.R



INOX.R

MOD.	676	678	679	680
H cm.	73	110	110	110
P Kg.	30,8	14	18	34,5
B cm.	75 x 50	Ø 40	Ø 45	Ø 60
C mm.	Ø 76	Ø 60	Ø 76	Ø 76
L cm.	max 180 x 110	max Ø 70	max Ø 70	max Ø 100

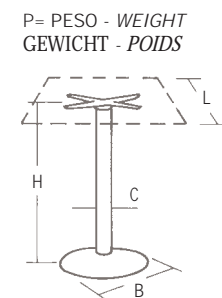

MOD.	684	686	688
H cm.	73	73	108
P Kg.	18	26	19,5
B cm.	40 x 40	75 x 40	40 x 40
C mm.	Ø 76	Ø 76	Ø 76
L cm.	max 90 x 90	max 140 x 85	max 70 x 70



INOX.R



INOX.R



INOX.R

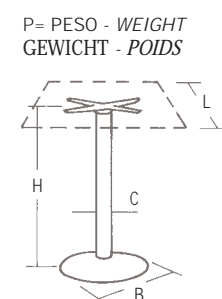

MOD.	690	691	693	694	696	697	698
H cm.	73	73	73	110	73	73	110
P Kg.	18	37,8	26	22	6,5	7,2	7,9
B cm.	40 x 40	60 x 60	75 x 40	40 x 40	62 x 62	75 x 75	75 x 75
C mm.	80 x 80	80 x 80	80 x 80	80 x 80	Ø 60	Ø 60	Ø 60
L cm.	max 90 x 90	max 120 x 120	max 140 x 85	max 70 x 70	max 80 x 80	max 90 x 90	max 80 x 80

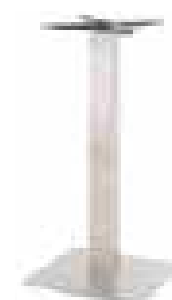

INOX.T



INOX.T

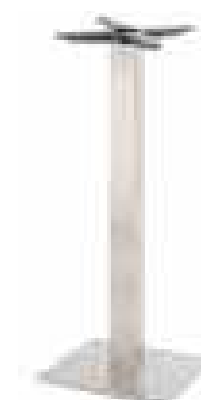

INOX.T

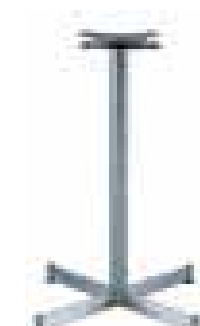

INOX.X

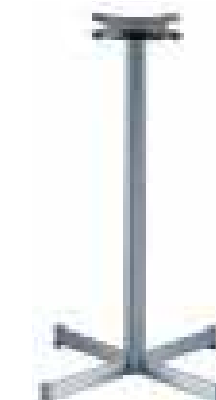

INOX.X

P= PESO - WEIGHT  
GEWICHT - POIDS

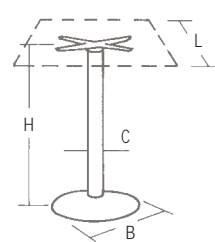

MARA

MARA

MARA

MARA

MOD.	720	721	728	729	731	736
H cm.	73	73	110	110	73	110
P Kg.	14,5	26,5	16,5	28	17	18,5
B cm.	Ø 42	Ø 59	Ø 42	Ø 59	42 x 42	42 x 42
C mm.	Ø 76	Ø 76	Ø 76	Ø 76	Ø 90	Ø 90
L cm.	max Ø 80	max Ø 140	max Ø 60	max Ø 110	max 80 x 80	max 60 x 60

P= PESO - WEIGHT  
GEWICHT - POIDS

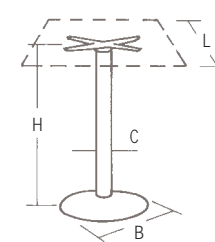

ONDA

ONDA

MOD.	700	701	702	703	707	708	709
H cm.	73	73	73	73	110	110	110
P Kg.	15	18,5	28	31,5	20	29,5	33
B cm.	Ø 35	Ø 40	Ø 55	Ø 60	Ø 40	Ø 55	Ø 60
C mm.	Ø 60	Ø 76	Ø 76	Ø 76	Ø 76	Ø 76	Ø 76
L cm.	max Ø 70	max Ø 85	max Ø 130	max Ø 150	max Ø 70	max Ø 100	max Ø 100

P= PESO - WEIGHT  
GEWICHT - POIDS

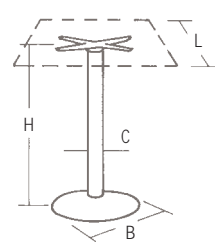

NEW

NEW

MOD.	732	733	734	743	744
H cm.	73	73	73	110	110
P Kg.	15	16	25	18	27
B cm.	Ø 40	Ø 46	Ø 56	Ø 46	Ø 56
C mm.	Ø 60	Ø 60	Ø 60	Ø 60	Ø 60
L cm.	max Ø 80	max Ø 90	max Ø 130	Ø 70	Ø 80

P= PESO - WEIGHT  
GEWICHT - POIDS

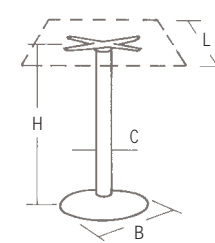

ONDA

ONDA

ONDA

ONDA

MOD.	704	705	710	711
H cm.	73	110	73	110
P Kg.	23	24,5	26	27,5
B cm.	40 x 40	40 x 40	60 x 41	60 x 41
C mm.	80 x 80	80 x 80	80 x 80	80 x 80
L cm.	max 90 x 90	max 70 x 70	max 140 x 90	max 120 x 70

P= PESO - WEIGHT  
GEWICHT - POIDS

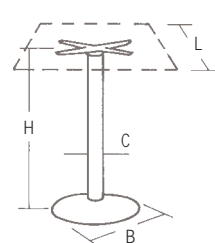

NEW

MOD.	735
H cm.	73
P Kg.	20
B cm.	40 x 40
C mm.	Ø 60
L cm.	max 80 x 80

P= PESO - WEIGHT  
GEWICHT - POIDS

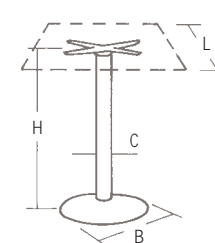

RANDA

RANDA

SILA

SILA

SILA

MOD.	724	725	726	727	745	746	747
H cm.	73	73	73	73	73	73	73
P Kg.	22,5	31	34,5	38,5	13,5	18	27
B cm.	Ø 40	Ø 55	Ø 60	76 x 46	Ø 56	42 x 42	70 x 70
C mm.	Ø 120	Ø 120	Ø 120	Ø 120			
L cm.	max Ø 90	max Ø 130	max Ø 150	max 150 x 90	max Ø 80	max 90 x 90 / Ø 110	max 120 x 120 / Ø 150

## PIANI TAVOLO IN LAMINATO - PLASTIC LAMINATE TOPS - KUNSTSTOFFPLATTEN - PLATEAUX EN STRATIFIÉ



Bordo ABS piatto.  
Flat ABS edge.  
ABS flache Kante.  
Chant ABS plat.

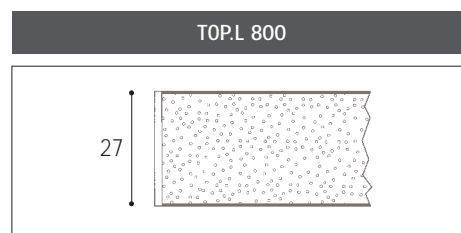

Bordo PVC stondato.  
Rounded PVC edge.  
Gerundete PVC Kante.  
Chant PVC rond.

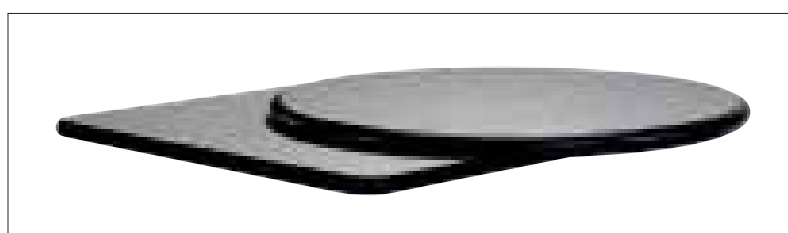
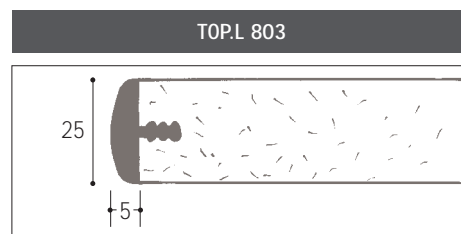

Bordo PVC tondo.  
Round PVC edge.  
Runde PVC Kante.  
Chant PVC rond.

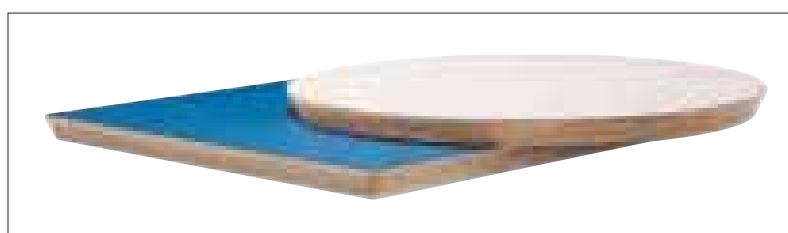
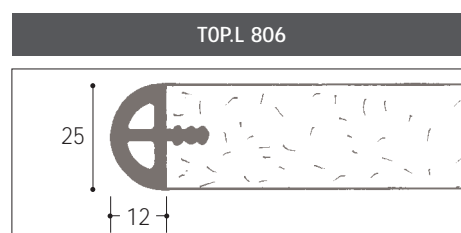

Bordo multistrati faggio inclinato.  
Plywood chamfered edge.  
Geneigte Schichtholz kante.  
Chant multiplis incliné.

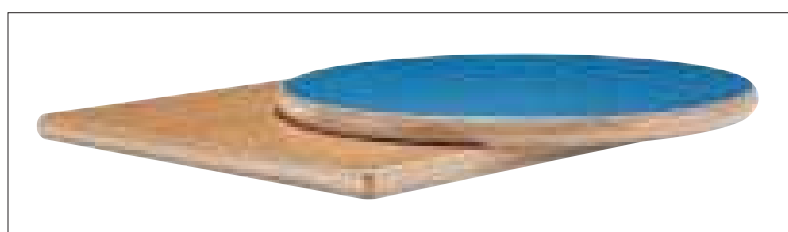
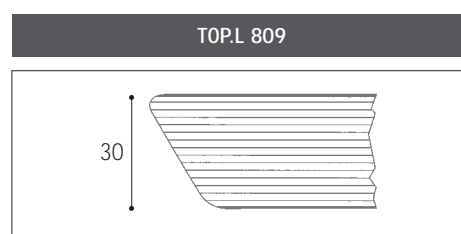

Bordo massello tondo.  
Solid round edge.  
Runde massive Kante.  
Chant massif rond.

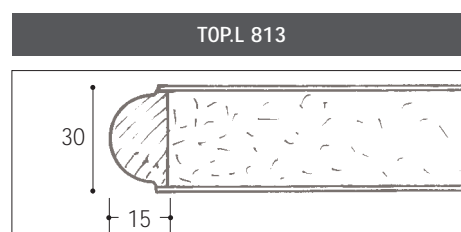
PIANI TAVOLO CON MOLLETTONE IMPERMEABILE - TOPS COVERED WITH WATERPROOF MOULTON  
TISCHPLATTEN MIT WASSERUNDURCHLÄSSIGEM MOULTON BEDECKT - PLATEAUX AVEC MOULTON

Bordo piatto.  
Flat edge.  
Flache Kante.  
Chant plat.

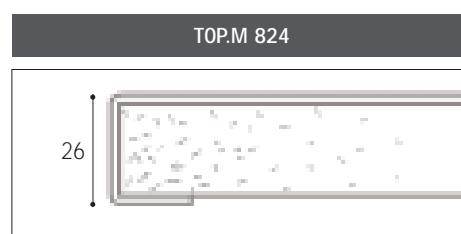

## PIANI TAVOLO IN STRATIFICATO - HPL LAMINATE TOPS - KOMPAKTPLATTEN - PLATEAUX STRATIFIÉS FORT-ÉPAISSEUR

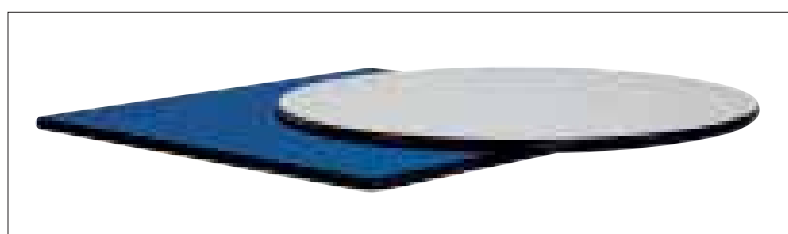

Bordo tondo.  
Round edge.  
Runde Kante.  
Chant rond.

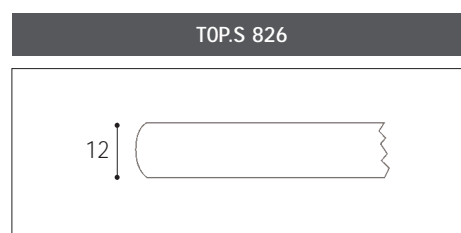

## PIANI TAVOLO IN TERMOFORMATO - HEAT MOULDED TOPS - HEISSE FORMTENPLATTEN - PLATEAUX TERMOFORMÉS

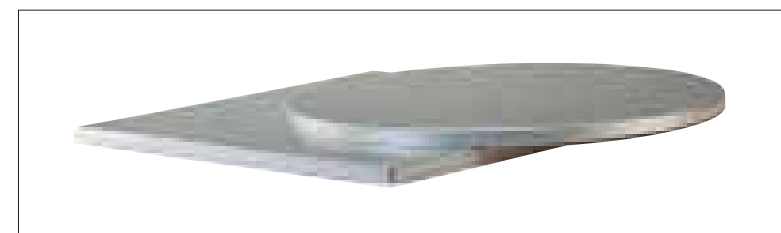

Bordo piatto.  
Flat edge.  
Flache Kante.  
Chant plat.

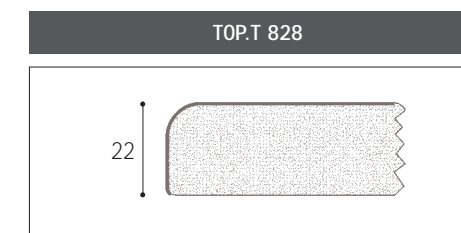
PIANI TAVOLO ESTENSIBILI IN LAMINATO - EXTENSIBLE PLASTIC LAMINATE TOPS  
DEHNBARE KUNSTSTOFFPLATTEN - PLATEAUX EXTENSIBLES EN STRATIFIÉ

Bordo in MDF.  
MDF edge.  
Kante aus MDF.  
Chant en MDF.

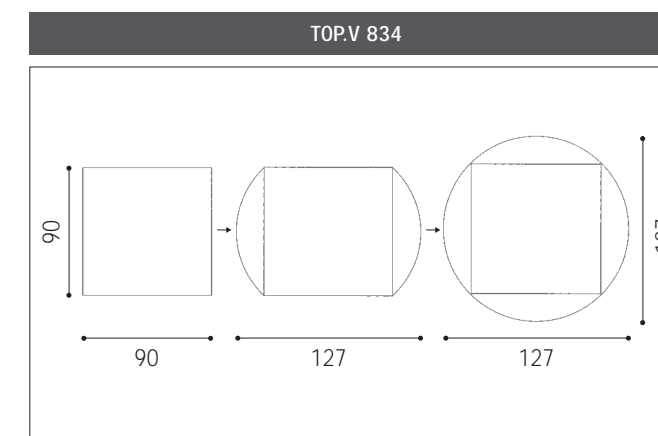
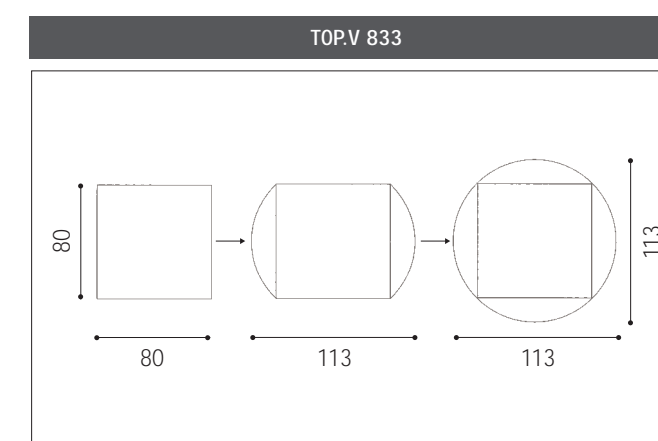
PIANI TAVOLO IMPIALLACCIATI IN LEGNO DI FAGGIO - BEECH VENEERED TOPS  
BUCHENPLATTEN FURNIERT - PLATEAUX PLAQUÉS EN HÊTRE

Bordo tondo.  
Round edge.  
Runde Kante.  
Chant rond.

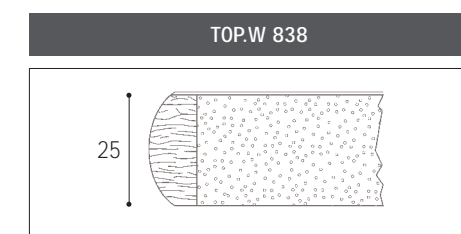

## PIANI TAVOLO IN VETRO - GLASS TOPS - GLASPLATTEN - PLATEAUX EN VERRE

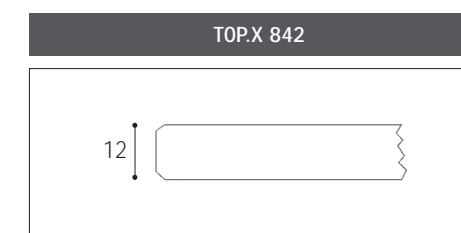
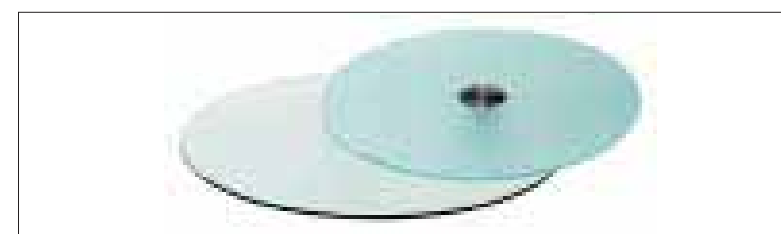



Tavoli per ristorante con fusto in faggio e piano in melaminico.  
*Restaurant tables with frame in beech and melamine top.*  
 Restaurant-Tische mit Gestell aus Buchenholz und Platte aus Melamin.  
*Tables en hêtre avec plateau en mélaminé.*

SALA 880.14

MOD.	MOD.	MOD.
876 cm. 80 x 120	880 cm. 80 x 80	883 Ø cm. 110
878 cm. 90 x 120	882 cm. 90 x 90	885 Ø cm. 160



SALA

Prolunga in melaminico.  
*Melamine extension.*  
 Verlängerung aus Melamin.  
*Allonge en mélaminé.*

MOD.	MOD.
896 cm. 80 x 80	898 cm. 80 x 120
897 cm. 90 x 90	899 cm. 90 x 120

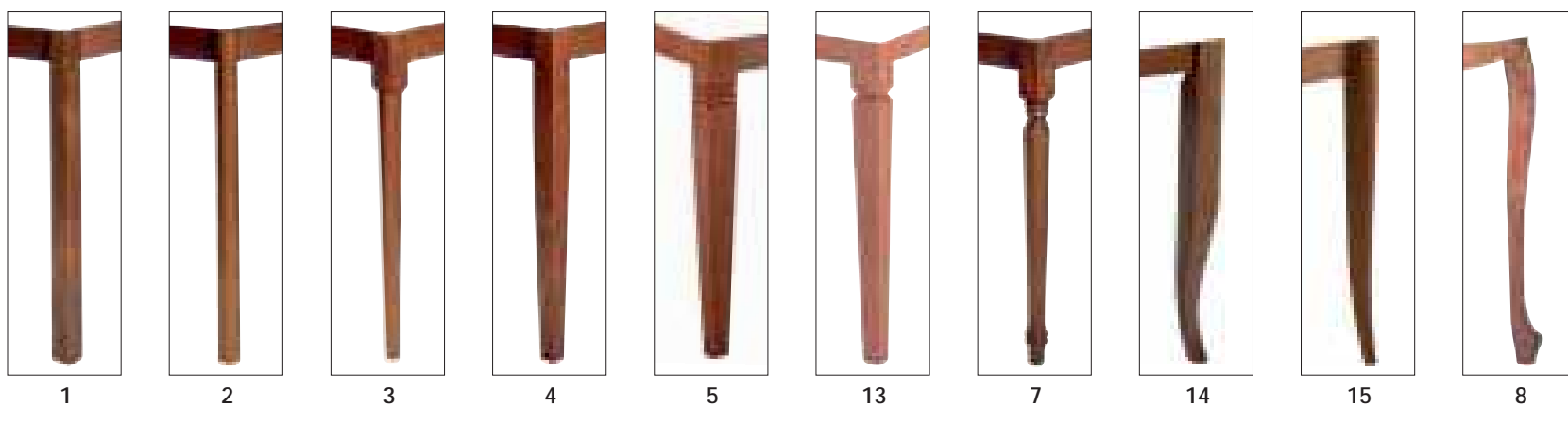

Finiture / rivestimenti / materiali  
*Finishes / coverings / materials*  
 Ausführungen / Stoffen / Farben  
*Finitions / tissus / matériaux*



SILVA 905 cm. 80 x 80 x 75 H



SILVA 907 cm. 70 x 70 x 45 H



TED 914 cm. 70 x 70 x 41 H



TED 916 cm. 130 x 70 x 41 H

## FINITURE SU LEGNO - WOOD FINISHES - HOLZFARBEN - FINITION SUR BOIS

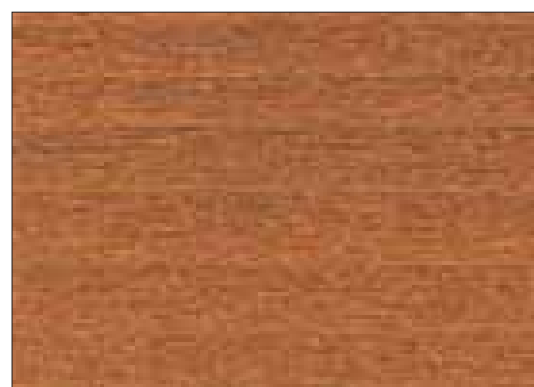
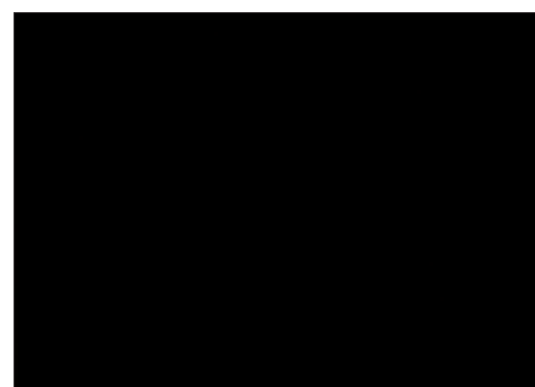
Faggio naturale - *Natural beech*  
Buche natur - *Hêtre naturel*Faggio tinto ciliegio P 87 - *Beech stained cherry P 87*  
Buche kirschbaumfarbig P 87 gebeizt  
*Hêtre teinté cerisier P 87*Faggio tinto ciliegio 07 - *Beech stained cherry 07*  
Buche kirschbaumfarbig 07 gebeizt  
*Hêtre teinté cerisier 07*Faggio tinto noce 4 - *Beech stained walnut 4*  
Buche nussbaumfarbig 4 gebeizt - *Hêtre teinté noyer 4*Faggio tinto noce 3 - *Beech stained walnut 3*  
Buche nussbaumfarbig 3 gebeizt - *Hêtre teinté noyer 3*Faggio tinto noce 1 - *Beech stained walnut 1*  
Buche nussbaumfarbig 1 gebeizt - *Hêtre teinté noyer 1*Faggio tinto mogano 5 - *Beech stained mahogany 5*  
Buche mahagonifarbig 5 gebeizt - *Hêtre teinté acajou 5*Faggio tinto wengé - *Beech stained wengé*  
Buche wengefarbig gebeizt - *Hêtre teinté wengé*Faggio anilina nera opaca - *Beech black mat Anilin*  
Buche schwarz matt Anilin - *Hêtre aniline noir satiné*Faggio decapé naturale - *Beech pickled pine*  
Buche entzundert - *Hêtre decapé naturel*Rovere sbiancato - *Bleached oak*  
Eiche hellfarbig gebeizt - *Chêne blanchi*Rovere tinto wengé - *Oak stained wengé*  
Eiche wengefarbig gebeizt - *Chêne teinté wengé*

## RIVESTIMENTI PER SEDUTE - COVERINGS FOR SEATINGS - STOFFEN FÜR STÜHLEN - TISSUS POUR CHAISES

**Categoria 1 - VINILPELLE IGNIFUGA "PLANET"** - 87,5% PVC e 12,5% cotone - Peso 640 g/mq - 20.000 cicli Martindale.

**Category 1 - FIRE RETARDANT VINYL "PLANET"** - 87.5% plasticized pvc and 12.5% cotton - Weight 640 g/smq - 20,000 Martindale rubs.

**Category 1 - SCHWERENTFLAMBARE PVC "PLANET"** - 87,5% plastifiziertes Pvc und 12,5% Baumwolle - Gewicht 640 g/m² - 20.000 Martindale Zyklen.

**Category 1 - TISSUS ENDUITS PVC IGNIFUGÉS "PLANET"** - 87,5% Pvc et 12,5% coton - Poids 640 g/m² - 20.000 cycles Martindale.

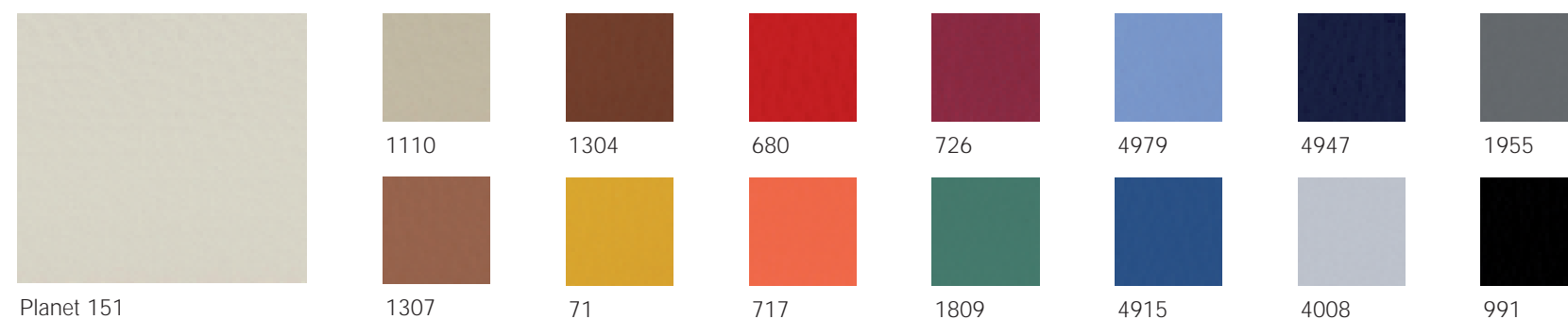

**Categoria 3 - MICROFIBRA IGNIFUGA "ALKEMIA PLUS/AU"** - 100% poliestere - Peso 620 g/mq - 50.000 cicli Martindale.

**Category 3 - FIRE RETARDANT MICROFIBRE "ALKEMIA PLUS/AU"** - 100% polyester - Weight 620 g/smq - 50,000 Martindale rubs.

**Category 3 - SCHWERENTFLAMBARE MIKROFASER "ALKEMIA PLUS/AU"** - 100% Polyester - Gewicht 620 g/m² - 50.000 Martindale Zyklen.

**Category 3 - MICROFIBRE IGNIFUGÉS "ALKEMIA PLUS/AU"** - 100% Polyester - Poids 620 g/m² - 50.000 cycles Martindale.

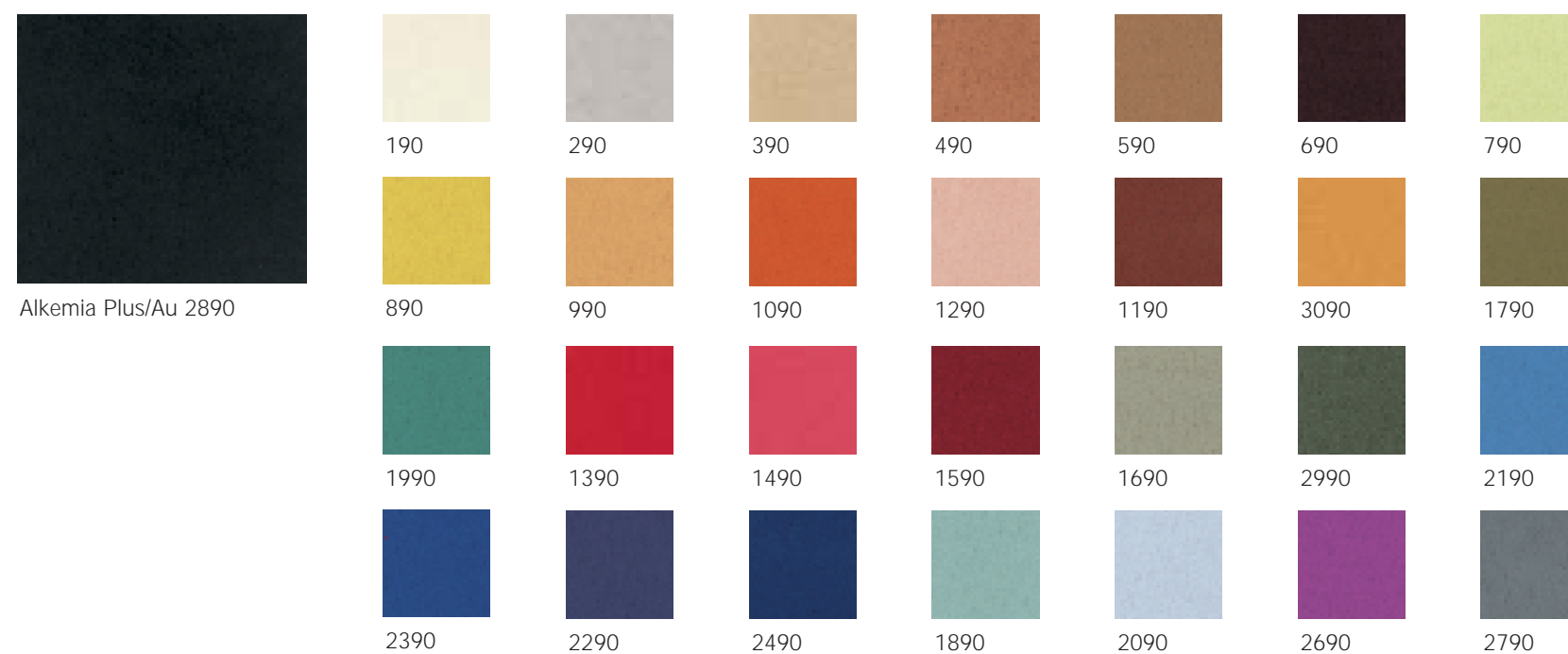

**Categoria 3 - TESSUTO IGNIFUGO "ANDROMEDA"** - 52% modacrilico e 48% poliestere - Peso 360 g/mq - 20.000 cicli Martindale.

**Category 3 - FIRE RETARDANT FABRIC "ANDROMEDA"** - 52% modacryl and 48% polyester - Weight 360 g/smq - 20,000 Martindale rubs.

**Category 3 - SCHWERENTFLAMBARE STOFF "ANDROMEDA"** - 52% Modacryl und 48% Polyester - Gewicht 360 g/m² - 20.000 Martindale Zyklen.

**Category 3 - TISSUS IGNIFUGÉS "ANDROMEDA"** - 52% modacryl et 48% polyester - Poids 360 g/m² - 20.000 cycles Martindale.

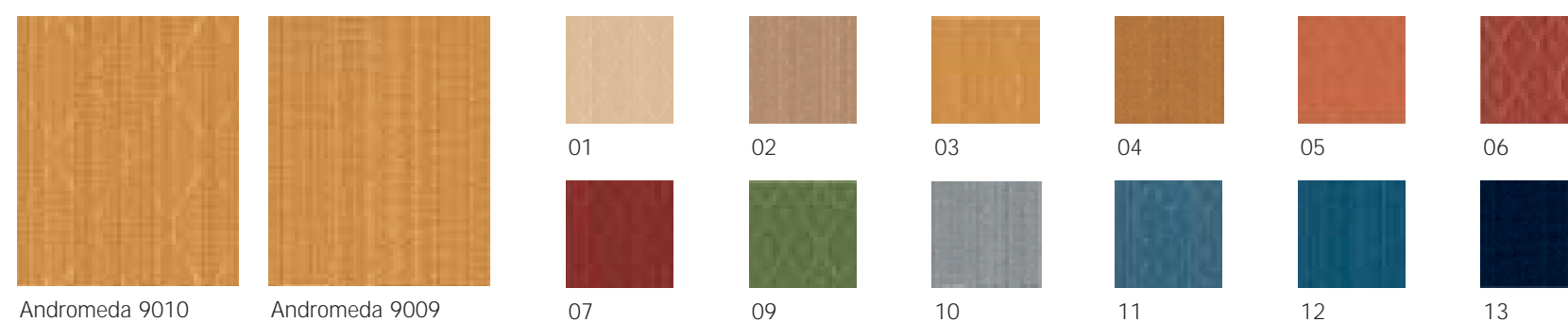

## FINITURE PER BASI TAVOLO - FINISHES FOR TABLE BASES - AUSFÜHRUNGEN FÜR TISCHSÄULEN - FINITIONS POUR PIÉMENTS

Finiture a polveri epossidiche per interni,  
per le basi tavolo di pag. 38 e 39.

*Epoxy powder coated finishes for indoors,  
for table bases of pages 38 and 39.*

Einbrennlackierte Ausführungen für Innen,  
für Tischsäulen in Seiten 38 und 39.

*Finitions en poudre époxy pour intérieur.*



Nero bucciato  
*Embossed black*  
Schwarz gaufriert  
*Noir bossé*



Bianco bucciato  
*Embossed white*  
Weiß gaufriert  
*Blanc bossé*

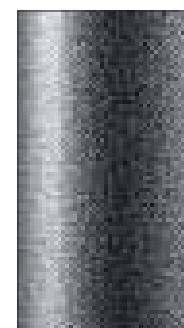

Grigio bucciato  
*Embossed grey*  
Grau gaufriert  
*Gris bossé*



Bronzo bucciato  
*Embossed bronze*  
Bronze gaufriert  
*Bronze bossé*

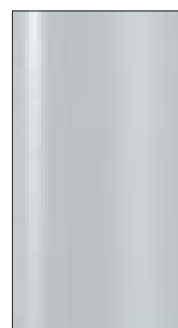

Alluminio  
*Aluminium*  
Aluminium  
*Aluminium*

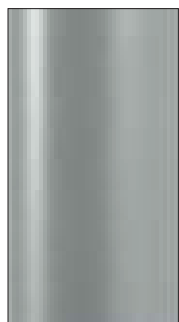

Ral 9007



Grigio naturale  
*Natural grey*  
Grau natur  
*Gris naturel*

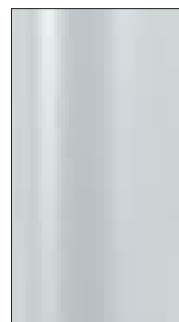

Alluminio gofrato  
*Embossed aluminium*  
Aluminium gaufriert  
*Aluminium bossé*

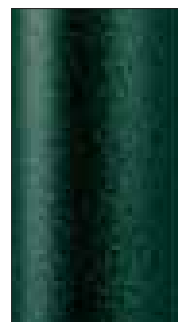

Verde gofrato  
*Embossed green*  
Grün gaufriert  
*Vert bossé*



Avorio gofrato  
*Embossed ivory*  
Elfenbein gaufriert  
*Ivorie bossé*

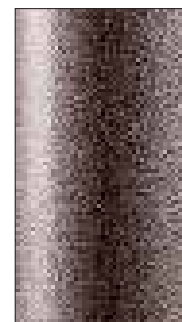

Marrone gofrato  
*Embossed brown*  
Braun gaufriert  
*Marron bossé*

Finiture cromata e inox per interni,  
per le basi tavolo di pag. 37, 38 e 39.

*Chromed and stainless steel finishes for  
indoors, for table bases of pages 37, 38  
and 39.*

Verchromte und Edelstahl Ausführungen  
für Innen, für Tischsäulen in Seiten 37, 38  
und 39.

*Finitions chromatisé et acier inoxydable  
pour intérieur.*

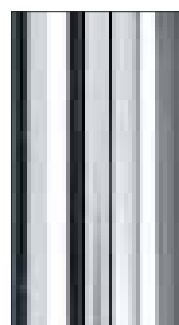

Cromato  
*Chromed*  
Verchromt  
*Chromatisé*

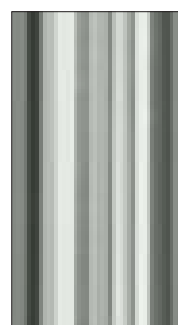

Inox satinato  
*Satin stainless steel*  
Satinierter Edelstahl  
*Acier inoxydable satin*

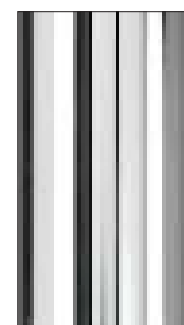

Inox lucido  
*Shiny stainless steel*  
Glänzender Edelstahl  
*Acier inoxydable brillant*

Finiture a polveri epossidiche per esterni,  
per le basi tavolo di pag. 38 e 39.

*Epoxy powder coated finishes for  
outdoors, for table bases of pages 38 and 39.*

Einbrennlackierte Ausführungen für Aussen,  
für Tischsäulen in Seiten 38 und 39.

*Finitions en poudre époxy pour extérieur.*

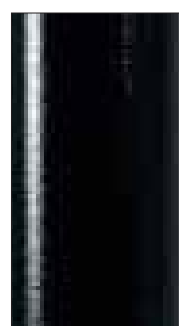

Nero  
*Black*  
Schwarz  
*Noir*

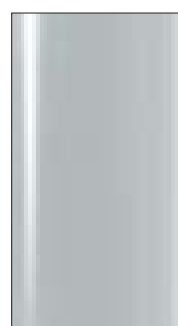

Ral 9006

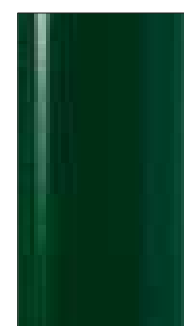

Ral 6005



Grigio  
Grey  
Grau  
Gris

## LAMINATI PLASTICI - PLASTIC LAMINATES - SCHICHTSTOFFEN - STRATIFIÉS

Laminati plastici per i piani tavolo di pag. 40. - *Plastic laminates for table tops of page 40.*  
Schichtstoffen für Tischplatten in Seite 40. - *Stratifié pour plateaux de page 40.*

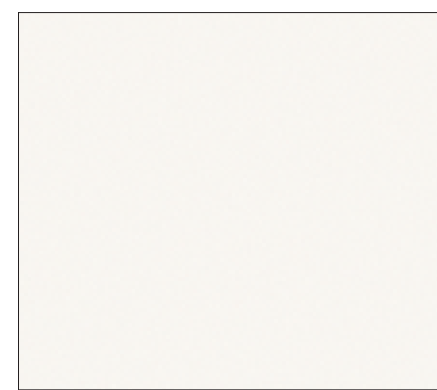

0020

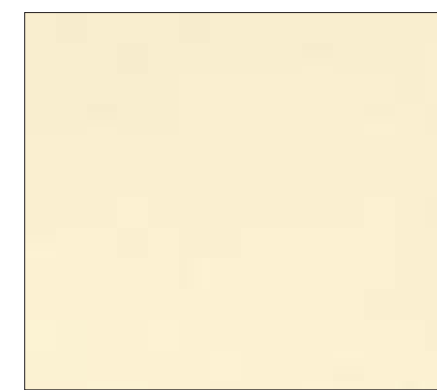

2440

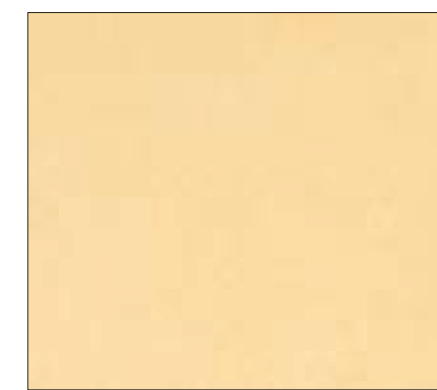

1100



1017



998



997

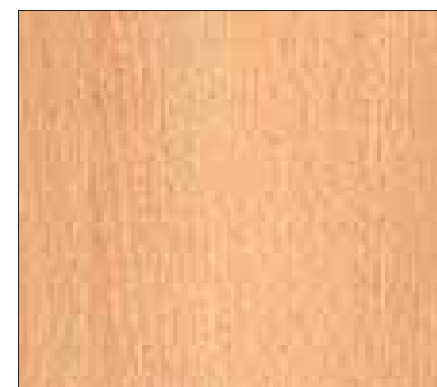

334



4150



1890



386



312

A richiesta possiamo fornire altri laminati  
della serie ARPA o ABET.

*On request we can supply other colours from  
ARPA or ABET ranges.*

Auf Wunsch kann man andere Laminatfarbe  
von ARPA oder ABET liefern.

*Sur demande on peut fournir autres  
stratifiés de chez ARPA ou ABET.*



**STRATIFICATI E TERMOFORMATI - HPL LAMINATES AND HEAT MOULDED TOPS**  
KOMPAKTPLATTEN UND HEISSE FORMTENPLATTE - *STRATIFIÉS FORT-EPAISSEUR ET THERMOFORMÉS*

Laminato plastico stratificato per i piani tavolo di pag. 40. - *HPL laminate tops for table tops of page 40.*  
Kompaktplatten für Tischplatten in Seite 40. - *Plateaux stratifiés fort-épaisseur pour plateaux de page 40.*

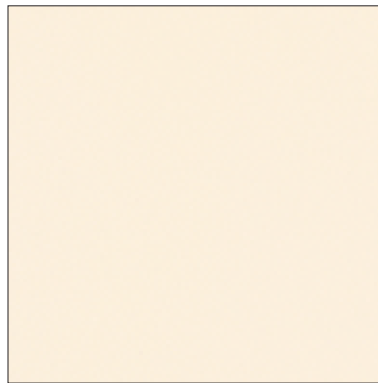

851



849

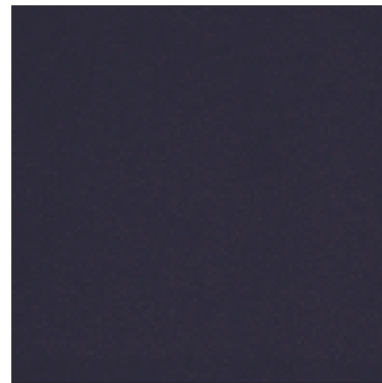

526

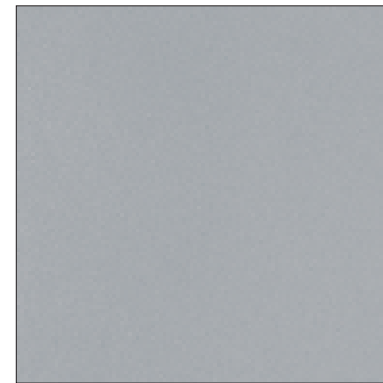

263

Termoformato per i piani tavolo di pag 41. - *Heat moulded top colours for table tops of page 41.*  
Heisse Formtenplatte für Tischplatten in Seite 41. - *Couleurs de plateaux thermoformés pour plateaux de page 41.*

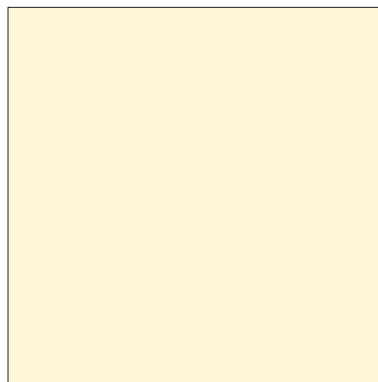

AV

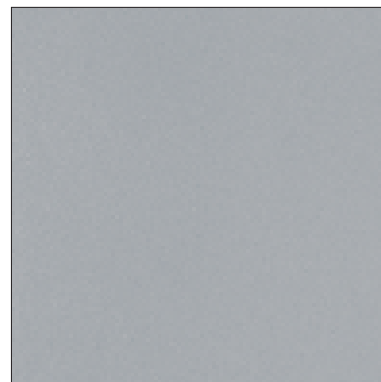

ARG



GA

I colori delle finiture e delle stoffe riprodotti in questo catalogo sono indicativi per le inevitabili differenze dovute alla riproduzione tipografica. I campionari illustrati possono essere soggetti a variazioni, senza alcun preavviso, dovute a necessità industriali o a un ulteriore miglioramento della qualità.

*The colours of finishes and fabrics are indicative because of the typographical reproduction. The illustrated collections can be modified without any notice because of industrial problems or quality improvements.*

Diese Ausführungen sind angehend. Die typographische Reproduktion bringt unvermeidliche Farbunterschiede! Die Muster können ohne Voranzeige wegen Herstellungsprobleme oder Qualitätsverbesserung geändert werden.

*Ces finitions sont indicatives. La reproduction typographique entraîne des différences inévitables. Les échantillons illustrés peuvent subir des changements, sans aucun préavis, dû à nécessités de production ou à une amélioration de la qualité.*